

## Componenti piede Inox per Cisterne

**Caratteristiche: BASI DAL PIENO CON NICCHIA, VITI E BOCCOLE**

**Features: SOLID BASES WITH NICHE, SCREWS AND SLEEVES**

CODICE - CODE	DIMENSIONI PRINCIPALI - MAIN DIMENSIONS				
	A	A1	G	F	H2
B40M20	40	32	5	M20	35
B40M24	40	32	5	M24	35
B50M24	50	45	10	M24	30
B50M30	50	45	10	M30	30
B60M20	60	54	10	M20	25
B60M24	60	54	10	M24	25
B60M30	60	54	10	M30	30
B60M40	60	54	10	M40	50
B80M24	80	75	10	M24	25
B80M30	80	75	10	M30	30
B80M40	80	75	10	M40	40

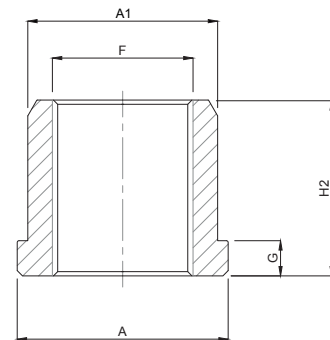

CODICE - CODE	DIMENSIONI PRINCIPALI - MAIN DIMENSIONS				
	F	H	H1	CHIAVE DI REGOLAZIONE REGULATION KEY	FORO DI REGOLAZIONE REGULATION HOLE
SM20-100	M20	70	100	17	
SM24-100	M24	70	100	20	
SM30-100	M30	70	100	26	
SM30-140	M30	100	140	26	
SM40-140	M40	100	140	36	
SM20-100F	M20	70	100		10,5
SM24-100F	M24	70	100		10,5
SM30-100F	M30	70	100		12,5
SM30-140F	M30	100	140		12,5
SM40-140F	M40	100	140		12,5

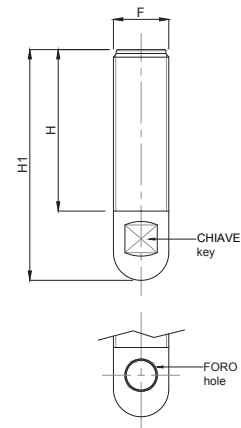

CODICE - CODE	DIMENSIONI PRINCIPALI - MAIN DIMENSIONS		
	D	H3	RAGGIO - RADIUS
P80M20	80	10	10 per M20
P100M24	100	10	12 per M24
P100M30	100	10	15 per M30
P120M30	120	10	15 per M30
P120M40	120	10	20 per M40
P150M30	150	15	15 per M30
P150M40	150	15	20 per M40
P200M40	200	15	20 per M40

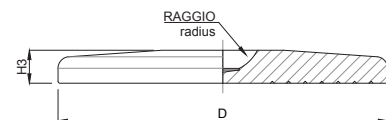

- Sistema di livellamento progettato per l'industria lattiero casearia, enologica, farmaceutica e alimentare nel rispetto delle più severe norme igieniche.
- Materiale base: acciaio inox AISI 304 (a richiesta AISI 316). Materiale stelo: acciaio inox AISI 304 (a richiesta AISI 316)
- *Leveling system planned for dairy, wine, pharmaceutical and food industry in respect of the strictest hygienic regulations.*
- *Material: Stainless steel 1.4301 (1.4401 on request)*